



MONDEO III htb (B4Y) saloon (B5Y)  
(excl. ST220, Titatnium, Platinum)

10/00-03/07

Cat. No. **E/033**

e20

e20\*94/20\*0353\*00

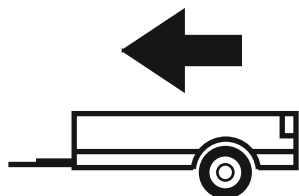

1800kg

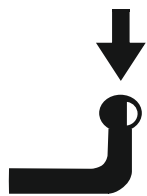

80kg

**D** = 11,00kN

**D (kN) =**



MAX kg

x

MAX kg

x 0,00981



MAX kg

+

MAX kg



IMIOLA HAK-POL

96-111 KOWIESY, CHOJNATA 23A, POLAND

Tel. + 48 46 831 73 31, fax +48 831 74 29

e-mail: office@imiola.pl, www.imiola.pl

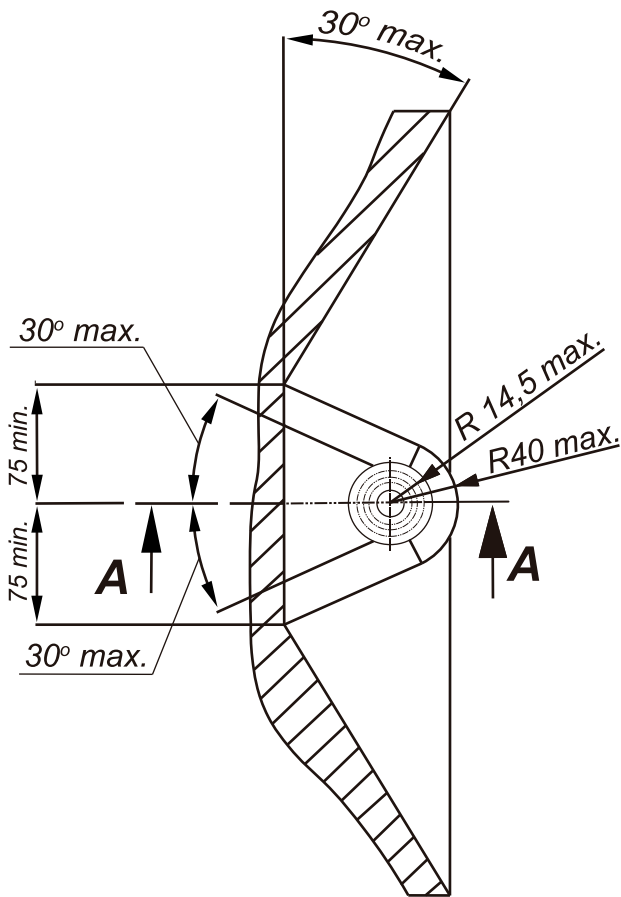

## PRZEKRÓJ A-A

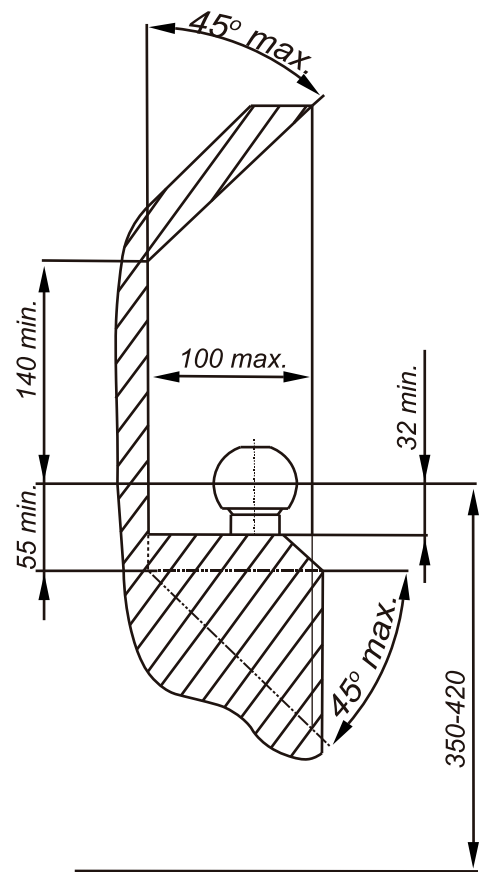

**PL** Należy zagwarantować przestrzeń swobodną według załącznika VII, rysunek 25a/b Regulaminu EKG ONZ 55.01 przy dopuszczalnym ciężarze całkowitym pojazdu.

**F** L'espace libre doit être garanti conformément à l'annexe VII, illustration de la réglementation 55.01 CE pour un poids total en charge autorisé du véhicule.







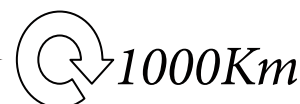

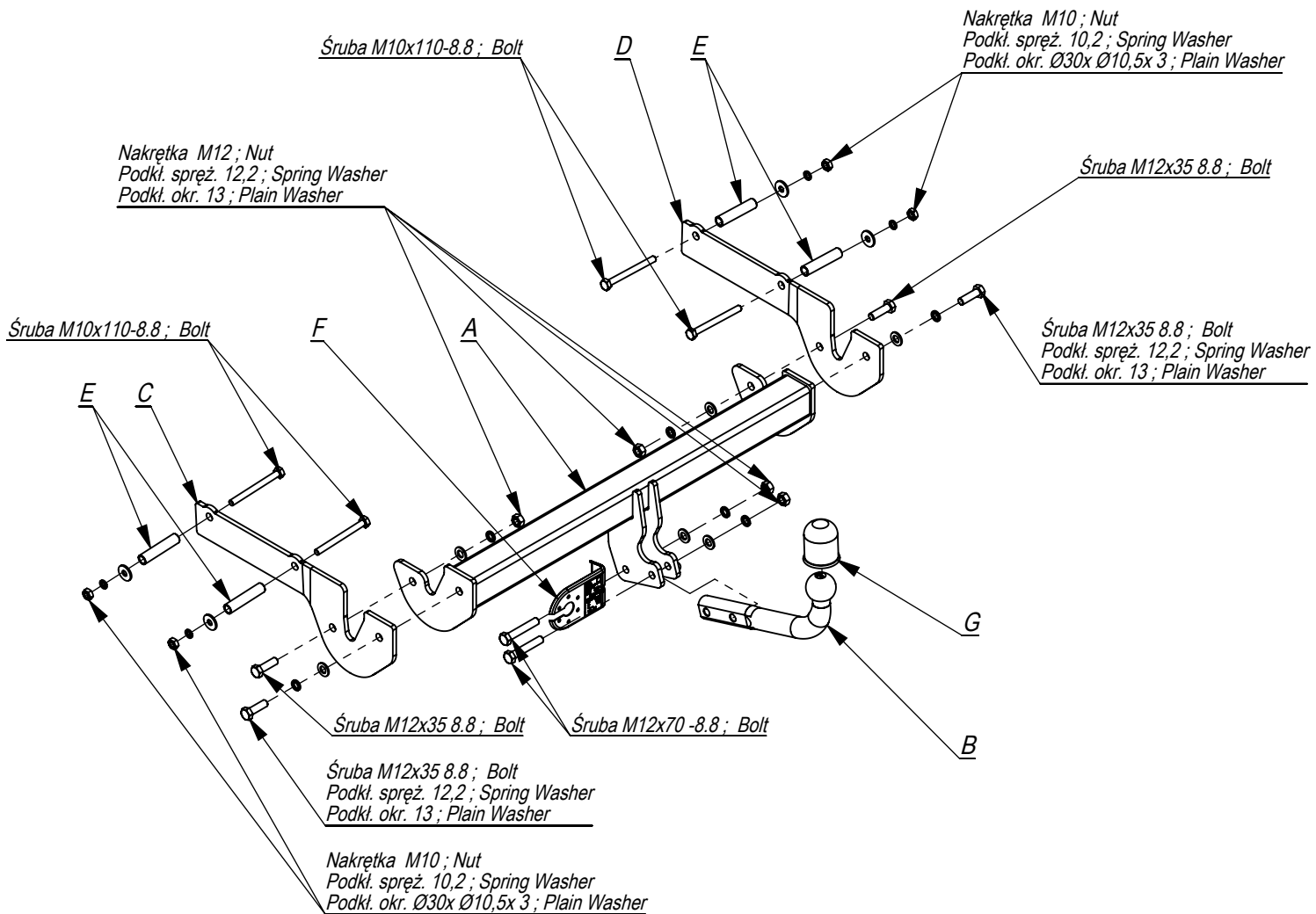

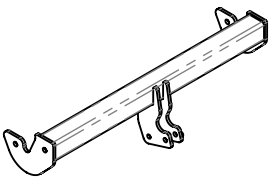
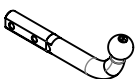
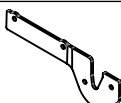

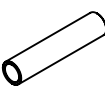
**GB** The clearance specified in appendix VII, diagram 25a/b of Regulation No. 55.01 UN EU must be guaranteed at laden weight of the vehicle.

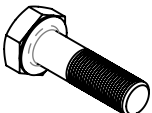
**D** Der Freiraum nach Anhang VII, Abbildung 25a/b der Vorschriften 55.01 EG ist zu gew 25a/b abzuwehren bei zulässigem Gesamtgewicht des Fahrzeuges.

Moment skręcający dla śrub i nakrętek (8.8) Torque settings for nuts and bolts (8.8)	
M8	25Nm
M10	55Nm
M12	85Nm
M14	135Nm
M16	195Nm





	A	x1		B	x1		C	x1		D	x1		E	x4		F	x1		G	x1		M12x70	2
																						M12x35	4
																						M10x110	4
										M12	4												
										M10	4												
							Ø30xØ10,5x3	4															
							13	6															
							12,2	6															
							10,2	4															



- Od spodu z prawej strony odkręcić plastikową osłonę.
- Odkręcić dolne mocowanie zderzaka. Wykonać wycięcie w dolnej części zderzaka wg szablonu.
- Opuścić tłumik z tylnego zawieszenia.
- Włożyć do podłużnic w technologiczne otwory tuleje dystansowe L=80
- Przykręcić do podłużnic elementy haka C śrubami M10x110 8.8 stosując nakładki E od zewnątrz podłużnic.
- Do elementów haka C przykręcić belkę haka A śrubami M12x35 8.8.
- Przykręcić kulę i blachę gniazda elektrycznego śrubami M12x70 8.8.
- Podłączyć instalację elektryczną.
- Dokręcić wszystkie śruby z momentem wg tabeli.
- Przykręcić zderzak oraz plastikową osłonę, założyć tłumik.

- Unscrew the plastic shield of the bottom from the right side.
- Unscrew the lower reinforcement of the bumper. Cut out the fragment in the lower part of the bumper according to the pattern.
- Remove the damper from the rear hanger.
- Insert the distance sleeves L=80 in the metal clamps, in the technological holes.
- Screw the elements C to the metal clamps with bolts M10x110 8.8 using plates E outside of the metal clamps.
- Screw the main bar A to the elements C with bolts M12x35 8.8.
- Fix the ball and electric plate with bolts M12x70 8.8.
- Connect the electric wires.
- Tighten all the bolts according to the torque setting- see the table.
- Screw the bumper and plastic shield, assemble the damper.

- Desserer la protection en plastique par le bas coté gauche.
- Desserer l'attache inférieur de pare-chocs. Ouvrir le pare-chocs en partie basse selon gabarit.
- Descendre le silencieux de la suspension arrière.
- Placer les douilles d'écartement L=80 dans les ouvertures de longerons.
- Serrer les éléments de crochet C aux longerons avec les boulons M10x110 8.8 en utilisant les palquettes E coté interne des longerons.
- Visser la traverse de crochet A aux éléments C de crochet par les boulons M12x35 8.8.
- Visser la boule et tôle de la prise électrique par les boulons M12x70 8.8.
- Raccorder le circuit électrique.
- Serrer tous les boulons avec un couple de serrage selon tableau.
- Serrer le pare-chocs et la protection en plastique, mettre le silencieux.

- Von unten auf der rechten Seite den Plastikschatz abschrauben.
- Die untere Befestigung der Stoßstange abschrauben. Einen Ausschnitt im unteren Teil der Stoßstange nach der Zeichnung ausführen.
- Den Ausputopf aus der hinteren Aufhängung entfernen.
- In die Längsträger, in die vom Werk aus vorhandenen Öffnungen, die Distanzhülsen L=80 stecken.
- An die Längsträger, die Tragteile C mit den Schrauben M10x110 8.8, mit der Anwendung von den Aufsätzen E von außen der Längsträger anschrauben.
- An die Tragteile C, den Querbalken A mit den Schrauben M12x35 8.8 anschrauben.
- Die Kugel und die Steckdosenhalterung mit den Schrauben M12x70 8.8 anschrauben.
- Die Elektroinstallation anschließen.
- Alle Schrauben mit dem in der Tabelle angegebenen Drehmoment festziehen.
- Die Stoßstange und den Plastikschatz anschrauben, den Ausputopf einbauen.

- Desenrosque la cubierta lateral derecha del chasis del automóvil.
- Retirar el silenciador de los colgadores.
- Meter los casquillos de separación E L= 80 en los orificios tecnológicos
- Introducir los elementos de la bola de remolque C y E en los largueros y, a través de los orificios tecnológicos en los largueros, atornillar ligeramente con tornillos M10x110 8.8 (p. 1), empleando arandelas ampliadas.
- Atornillar la viga de la bola de remolque A con los elementos C, usando tornillos M12x35 8.8 (p. 2).
- Cortar la parte inferior del parachoques, en su eje, para una abertura para el soporte del balón.
- Apretar todos los tornillos con el par según la tabla anterior.
- Apretar el parachoques.
- Apretar la bola y la placa eléctrica con tornillos M12x70 8.8. (p. 3).
- Conectar la instalación eléctrica.

